



Séries
NSX

SIZE 1 COAXIAL SOCKET CONTACT
FOR RG214 AND RG 393 CABLES
BOEING P/N BACC 47 EN-1A AND 2A

Issue:
22 APRIL 93

Page
1 / 1

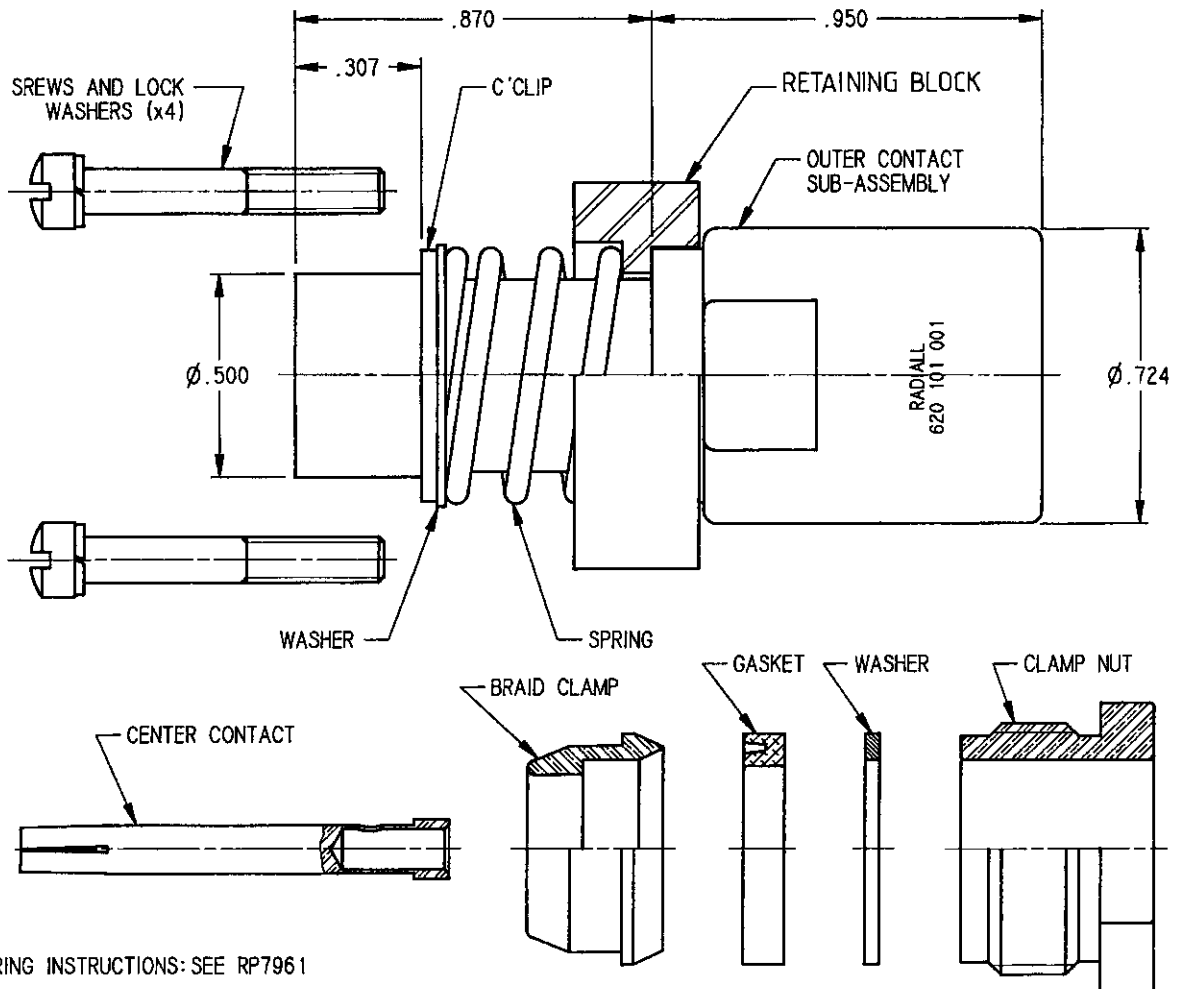

WIRING INSTRUCTIONS: SEE RP7961

LOCK WASHERS	SPRING STEEL	CADMIUM YELLOW CHROMATE
SCREWS	STAINLESS STEEL	PASSIVATED
FLAT WASHERS	STAINLESS STEEL	PASSIVATED
SPRING	STAINLESS STEEL MUSIC WIRE	PASSIVATED
RETAINING BLOCK	ALUMINUM ALLOY PER QQ.A.591	BLACK ANODIZED BY MIL.A.8625
GASKET	FLUOROSILICONE PER MIL.R.25988	NONE
DIELECTRIC	PTFE PER MIL.S.19468	NONE
CENTER CONTACT	BERYLLIUM COPPER PER QQ.C.530 HEAT TREATED	.00004 GOLD PER MIL.G 45204 OVER .0001 OF NICKEL PER QQ.N.290
OUTER CONTACT BODY BRAID CLAMP_WASHERS CLAMP NUT	BRASS PER QQ.B.626	.00002 GOLD PER MIL.G 45204 OVER .0001 OF NICKEL PER QQ.N.290
COMPONENT DESIGNATION	MATERIAL	FINISH

CREATION			
PEN: .			
EP: .			
Name: JP MACARI			
Date: 22 APRIL 93			
Issue	Revisions		Name

This information is given as an indication in the continual goal to improve our products. We reserve the right to make any modifications judged necessary.

4112_9212